



Designation: D1052 – 09 (Reapproved 2019)

Standard Test Method for Measuring Rubber Deterioration—Cut Growth Using Ross Flexing Apparatus¹

This standard is issued under the fixed designation D1052; the number immediately following the designation indicates the year of original adoption or, in the case of revision, the year of last revision. A number in parentheses indicates the year of last reapproval. A superscript epsilon (ϵ) indicates an editorial change since the last revision or reapproval.

This standard has been approved for use by agencies of the U.S. Department of Defense.

1. Scope

1.1 This test method covers a test for measuring the cut growth in rubber vulcanizates subjected to repeated bend flexing.

1.2 The values stated in SI units are to be regarded as the standard. The values given in parentheses are for information only.

1.3 *This standard does not purport to address all of the safety concerns, if any, associated with its use. It is the responsibility of the user of this standard to establish appropriate safety, health, and environmental practices and determine the applicability of regulatory limitations prior to use.*

1.4 *This international standard was developed in accordance with internationally recognized principles on standardization established in the Decision on Principles for the Development of International Standards, Guides and Recommendations issued by the World Trade Organization Technical Barriers to Trade (TBT) Committee.*

2. Referenced Documents

2.1 *ASTM Standards:*²

[D573 Test Method for Rubber—Deterioration in an Air Oven](#)

[D1349 Practice for Rubber—Standard Conditions for Testing](#)

[D3183 Practice for Rubber—Preparation of Pieces for Test Purposes from Products](#)

[D3767 Practice for Rubber—Measurement of Dimensions](#)

3. Summary of Test Method

3.1 A pierced strip test specimen is bent freely over a rod to a 90° angle and the cut length is measured at frequent intervals,

¹ This test method is under the jurisdiction of ASTM Committee D11 on Rubber and Rubber-like Materials and is the direct responsibility of Subcommittee D11.15 on Degradation Tests.

Current edition approved Nov. 1, 2019. Published December 2019. Originally approved in 1949. Last previous edition approved in 2014 as D1052 – 09 (2014). DOI: 10.1520/D1052-09R19.

² For referenced ASTM standards, visit the ASTM website, www.astm.org, or contact ASTM Customer Service at service@astm.org. For *Annual Book of ASTM Standards* volume information, refer to the standard's Document Summary page on the ASTM website.

to determine the cut growth rate. The cut is initiated by a special shaped piercing tool.

4. Significance and Use

4.1 The test gives an estimate of the ability of rubber vulcanizates to resist crack growth of a pierced specimen when subjected to bend flexing.

4.2 No exact correlation between these test results and service is implied due to the varied nature of service conditions.

5. Apparatus

5.1 *Ross Flexing Machine*—The machine, as illustrated in [Fig. 1](#) and [Fig. 2](#), allows one end of the test specimen to be clamped firmly to a holder arm while the pierced end is placed between two rollers that must permit a free bending movement of the test specimen during the test. During each cycle, the pierced area of the test specimen is bent freely over a 10-mm (0.4 in.) diameter rod through a 90° angle. The machine shall operate at 1.7 ± 0.08 Hz (100 ± 5 cpm).

5.2 *Piercing Tool and Holder*, as shown in [Fig. 3](#).

5.3 *Measuring Instrument*, having graduations, or a resolution, capable of measuring the *cut length* and *cut growth*, as described in [8.4](#) and [8.5](#), to the nearest 0.5 mm (0.02 in.).

5.4 *Thickness Gage*, as described and specified in Practice [D3767](#), Procedure A, to measure the thickness of the test specimen as described in [8.1](#).

6. Test Specimens

6.1 At least two, preferably three, test specimens of each sample shall be tested simultaneously.

6.1.1 The test specimens shall be 25 ± 1 mm (0.98 ± 0.04 in.) in width, a minimum of 152 mm (5.98 in.) in length, and 6.35 ± 0.03 mm (0.25 ± 0.01 in.) in thickness, and shall be cut from a vulcanized sheet 6.35 ± 0.03 mm (0.25 ± 0.01 in.) in thickness and of suitable dimensions or from finished articles by cutting and buffing. If obtained from a manufactured article, the piece of rubber shall be free of surface roughness, fabric layers, and the like, in accordance with the procedure described in Practice [D3183](#).

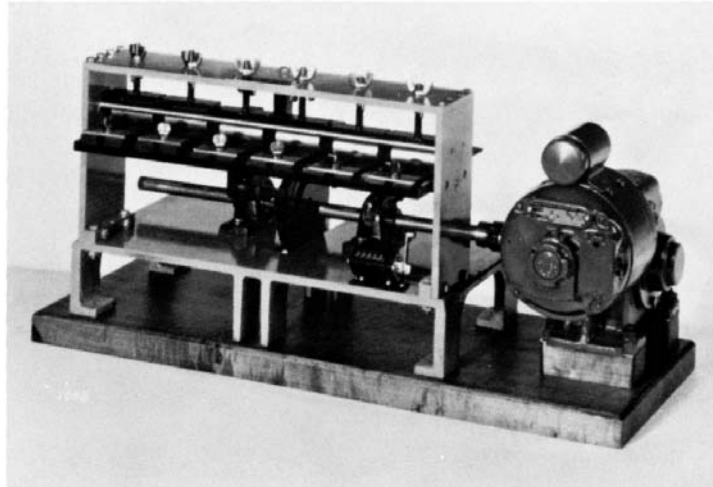
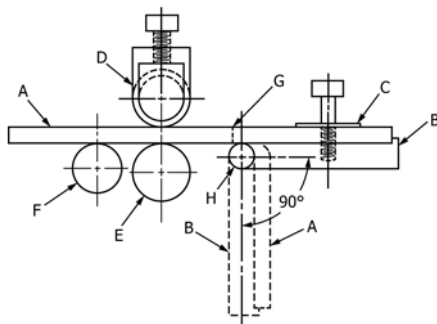

FIG. 1 Ross Flexing Machine



- A—Test Specimen.
- B—Holder arm.
- C—Holder arm adjustment.
- D—Adjustable top roller.
- E—Fixed lower roller.
- F—Supporting fixed lower roller.
- G—Pierced section.
- H—10 mm (0.375 in.) diameter rod over which specimen bends freely through a 90° angle.

FIG. 2 Schematic Diagram of Ross Flexing Machine

6.1.2 Unless otherwise specified, the test specimens shall be prepared so that the longitudinal dimension is parallel with the direction of the milling grain.

NOTE 1—When specimens of high hardness are being tested, a thickness other than standard may be used as agreed upon between the supplier and the consumer.

6.2 Unless otherwise specified, the test specimens shall be aged for 24 h at 100°C (212°F) in accordance with Test Method D573 and then allowed to remain in the Standard Laboratory Atmosphere in accordance with Practice D1349, having a relative humidity of $50 \pm 5 \%$ and a temperature of $23 \pm 2^\circ\text{C}$ ($73 \pm 3.6^\circ\text{F}$), for a period of 16 to 96 h.

6.3 The test specimens shall be pierced by use of the piercing tool.³ The piercing tool shall be adjusted in the holder with the cutting edge projecting 7.0 ± 0.3 mm (0.275 ± 0.010 in.) from the base of the holder so that it will pierce completely through the test specimens when tapped. Before piercing each test specimen, the piercing tool shall be lubricated with a soap solution that will not react with the rubber. The cut made by the piercing tool shall be parallel to the width of the test specimen, at a right angle to and across the longitudinal center line of the specimen at a 62 ± 2 mm (2.44 ± 0.05 in.) distance from the clamped end.

7. Test Temperature

7.1 Unless otherwise specified, the test temperature shall be $23 \pm 2^\circ\text{C}$ ($73 \pm 3.6^\circ\text{F}$).

8. Procedure

8.1 Measure and record the median thickness of the test specimen taken at three points across the width at the point of the cut in accordance with Procedure A of Practice D3767.

8.2 With the holder arm of the flexing machine in a horizontal position, clamp side by side the test specimens of the same making sure that the cuts are at the center point of the arc of the rod.

8.3 Lower the adjustable top rollers until they just touch the test specimen and lock in this position by means of the wing nuts, permitting free travel of the test specimens between the rollers during the bending movement. The position of the test specimen is shown in Fig. 2.

³ The sole source of supply of the piercing tool and apparatus known to the committee at this time is CCSI, 221 Beaver St., Akron, OH 44304. If you are aware of alternative suppliers, please provide this information to ASTM International Headquarters. Your comments will receive careful consideration at a meeting of the responsible technical committee,¹ which you may attend.